

hr387MXGE

HR 10 GigE



The HR 10 GigE series with its high-end high-resolution CCD and CMOS sensors permits making full use of the sensor bandwidth. 10 GigE delivers up to 1.1 GB/s of image data with distances up to 100m .

The clean design according to well established standards like GigE Vision, 10 GigE Vision and GenICam ensure rapid integration into the final application. The camera features a rich choice of industrial hardware and software features. Burst mode enables even higher trigger frequencies.

Best suited for applications such as optical metrology, surface control, quality control or monitoring of large areas.

Technical Highlights

- > Defect pixel correction, lens shading correction
- > ROI, LUT, binning, gamma, offset, autoexposure
- > GenICam interface with GenTL driver
- > Integrated multi channel LED strobe controller
- > POE (Power Over Ethernet) single cable option
- > Industrial TTL-24V I/O interface with SafeTrigger, programmable logic functions, sequencer and timer, RS232
- > M58 lens interface (F-Mount optional)

HR Series

hr387MXGE

Resolution [MP]	16.7 MP
Resolution (h x v)	5440 x 3076 px
Frame rate (max.)	56.4 fps
Chroma	mono
Interface	10GigE (RJ-45)

Sensor

Sensor	IMX387LLA
Manufacturer	Sony
Sensor type	Area CMOS
Shutter type	global shutter
Sensor size (h x v)	18.77 x 10.61 mm
Optical diagonal	21.56 mm
Sensor format	21.7mm (4/3)
Pixel size (h x v)	3.45 x 3.45 μm

Camera

Exposure modes	MANUAL;AUTO;EXTERNAL
Trigger modes	INTERNAL;SOFTWARE;EXTERNAL
Exposure time (min)	21 μs
Exposure time (max)	1 sec (external ∞)
Pixel format / max	mono8, mono12 / 12 bit
Gain modes / max	manual, auto / 18 dB
Internal memory	512 MB SDRAM, 32 MB Flash

Feature Set

LUT	yes
Offset	yes
Binning	yes
Image flip	yes
Shading correction	yes (external)
Defect pixel correction	yes
Sequencer	yes
POE	yes (POE+)(optional)

Housing

Lens mount	M58x0.75
Dimensions (w x h x d)	70 x 70 x 79.8 mm
Weight	400 g
Ambient temperature	-10 to 45 °C
Protection class	IP30
Filter-/Coverglass	N-BK7 - AR coating 380-850nm

I/O-Interfaces

Input up to 24V	2 x
Input OPTO	1 x
Output open drain	4 x
I/O RS-232	1 x
Power supply	10 to 25 V (DC)
Power consumption	15.5 W (dep. on operating mode)

Dimensions [mm]

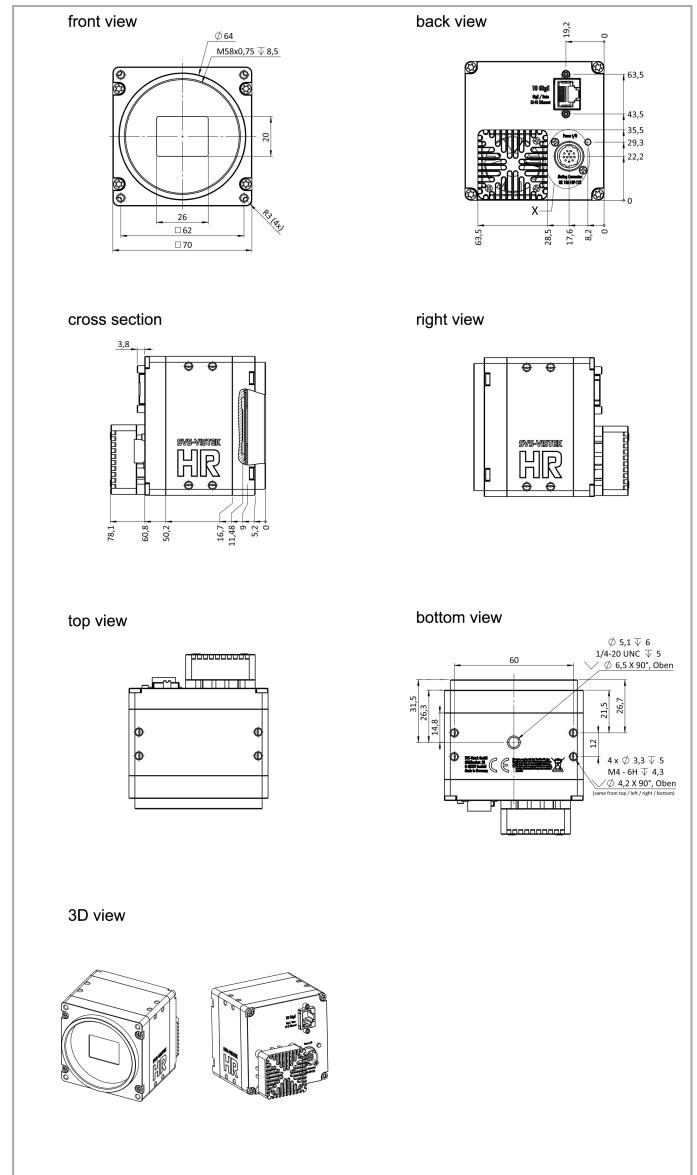

Pinout Mating Connector

Hirose 12 Pin	1	VIN - (GND)	7	OUT 1 (open drain)
	2	VIN + (10 V to 25 V DC)	8	OUT 2 (open drain)
	3	IN 4 (RXD RS232)	9	IN 3 + (opto In +)
	4	OUT 4 (TXD RS232)	10	IN 3 - (opto In -)
	5	IN 1 (0-24V)	11	OUT 3 (open drain)
	6	IN 2 (0-24V)	12	OUT 0 (open drain)

Spectral Response *

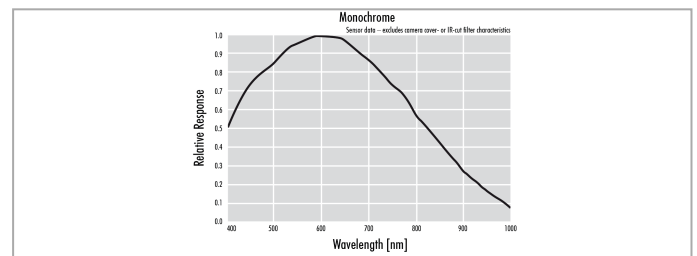

* Sensor data – excludes camera cover- or IR-cut filter characteristics

