

# hr49MCX12

HR CoaXPress



The interface standard CoaXPress was developed to meet the need for higher bandwidth generated by recently launched sensors. In particular the latest high resolution CMOS sensors from Sony, Gpixel and ON Semi are capable of extremely high frame rates. CoaXPress therefore is the first choice for applications where speed is of prime importance.

## Technical Highlights

- > ROI, LUT, binning, offset, gamma
- > Lens shading correction
- > Integrated multi channel LED strobe controller
- > CoaXPress-6 or CoaXPress-12
- > Industrial TTL-24V I/O Interface with SafeTrigger, programmable logic, sequencer and timers, RS232
- > Power over CXP

## HR Series

## hr49MCX12

Resolution [MP]	49 MP
Resolution (h x v)	7008 x 7000 px
Frame rate (max.)	71 fps
Chroma	mono
Interface	CXP-12 with 4 Connections (micro-BNC)

### Sensor

Sensor	GMAX3265-49
Manufacturer	Gpixel
Sensor type	Area CMOS
Shutter type	global shutter
Sensor size (h x v)	22.43 x 22.4 mm
Optical diagonal	31.7 mm
Sensor format	37.4mm
Pixel size (h x v)	3.2 x 3.2 $\mu\text{m}$

### Camera

Exposure modes	MANUAL;AUTO
Trigger modes	INTERNAL;SOFTWARE;EXTERNAL
Exposure time (min)	12 $\mu\text{s}$
Exposure time (max)	1 sec
Pixel format / max	mono8, mono10 / 10 bit
Gain modes	manual, auto
Internal memory	1024 MB SDRAM, 160 MB Flash

### Feature Set

AOI	yes
LUT	yes
Offset	yes
Binning	yes
Image flip	yes
Shading correction	yes (external)
Defect pixel correction	yes
Sequencer	yes

### Housing

Lens mount	M58x0.75
Dimensions (w x h x d)	70 x 70 x 75.9 mm
Weight	420 g
Operating temperature (housing)	-10 to 65 °C
Ambient humidity	10 to 90 % (non-condensing)
Protection class	IP30

### I/O-Interfaces

Input up to 24V	2 x
Input OPTO	1 x
Output open drain	4 x
I/O RS-232	1 x
Power supply	10 to 25 V (DC)
Power consumption	14 W (dep. on operating mode)

## Dimensions [mm]

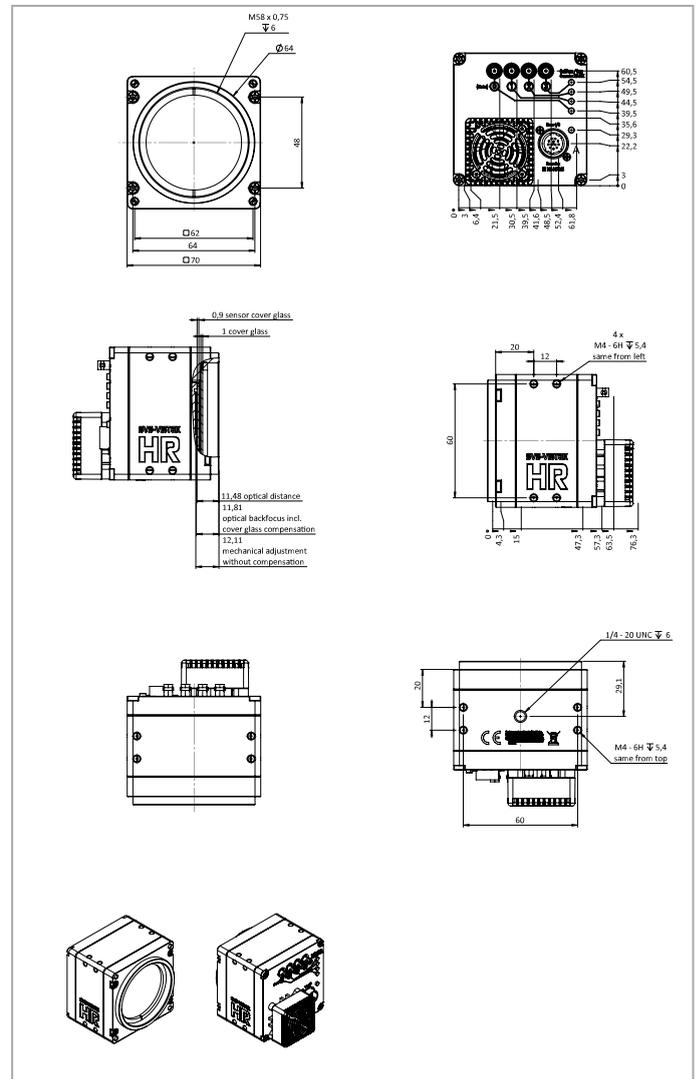

## Pinout Mating Connector

Hirose 12 Pin	1	2	3	4	5	6	7	8	9	10	11	12
	VIN -	VIN +	IN 4	OUT 4	IN 1	IN 2	OUT 1	OUT 2	IN 3 +	IN 3 -	OUT 3	OUT 0
	(GND)	(10 V to 25 V DC)	(RXD RS232)	(TXD RS232)	(0-24V)	(0-24V)	(open drain)	(open drain)	(opto In +)	(opto In -)	(open drain)	(open drain)

## Spectral Response \*

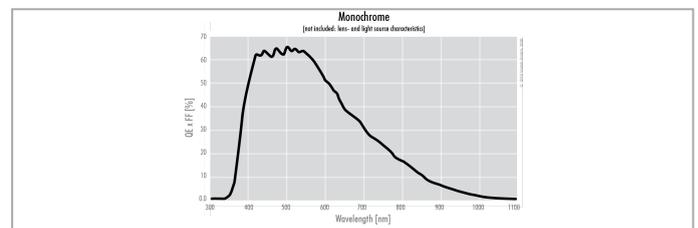

\* Sensor data – excludes camera cover- or IR-cut filter characteristics

